



**What we offer**  
**Customised & Modular assessment solutions for schools, universities, awarding bodies & businesses.**

**Who are we?**  
**Certify Assessment Solutions specialises in next-generation software solutions for education & business.**

**Check out our Invigilate video here!**



**Data Analytics**  
 Our CBT software analyses question performance, optimises tests and randomises questions to make them fairer and more secure.

**SmartTest invigilate**  
 SmartTest Invigilate is an advanced white-label remote invigilation platform which can be used with both human invigilators and AI. It can be fully integrated into your current learning or assessment platforms.

**AI Flagging Feature**  
 The AI feature will automatically flag suspicious activity for subsequent human review.

**Record & Review**  
 Allows tests to be recorded for subsequent assessment.

**Live Invigilation**  
 Real-time invigilation to monitor and record sessions with mobile camera settings to support practical assessments.

**SmartTest examiner**  
 Examiner is a powerful white-label e-assessment platform with one-touch publishing and a wide array of item types and post-test performance reporting features. It can be used from any classroom or from home.

**Customisation**  
 Our powerful white-label solution can be customised to your needs. We will train you to become autonomous with your own instance of the platform. We will provide you with as much or as little support as you need.

**Registration Portal**  
 Our streamlined service allows for swift transactions between the portal and the payment gateway, so students can quickly register for an exam. It can also be used for voucher-based registration.

**SmartTest NEXUS**  
 Nexus is our white-label assessment ERP portal which can be integrated with your platforms to manage your students and the test and assessment process.

**360° Facilitation**  
 Nexus simplifies the journey for students, teachers and invigilators alike, allowing them to easily create profiles, schedule exams and track their performance

**Tech that empowers education, service that empowers teachers & students – That's Our Promise.**

**Come visit us at Stand SH30**  
**We promise it'll be more fun than an exam!**



# BOMMAC

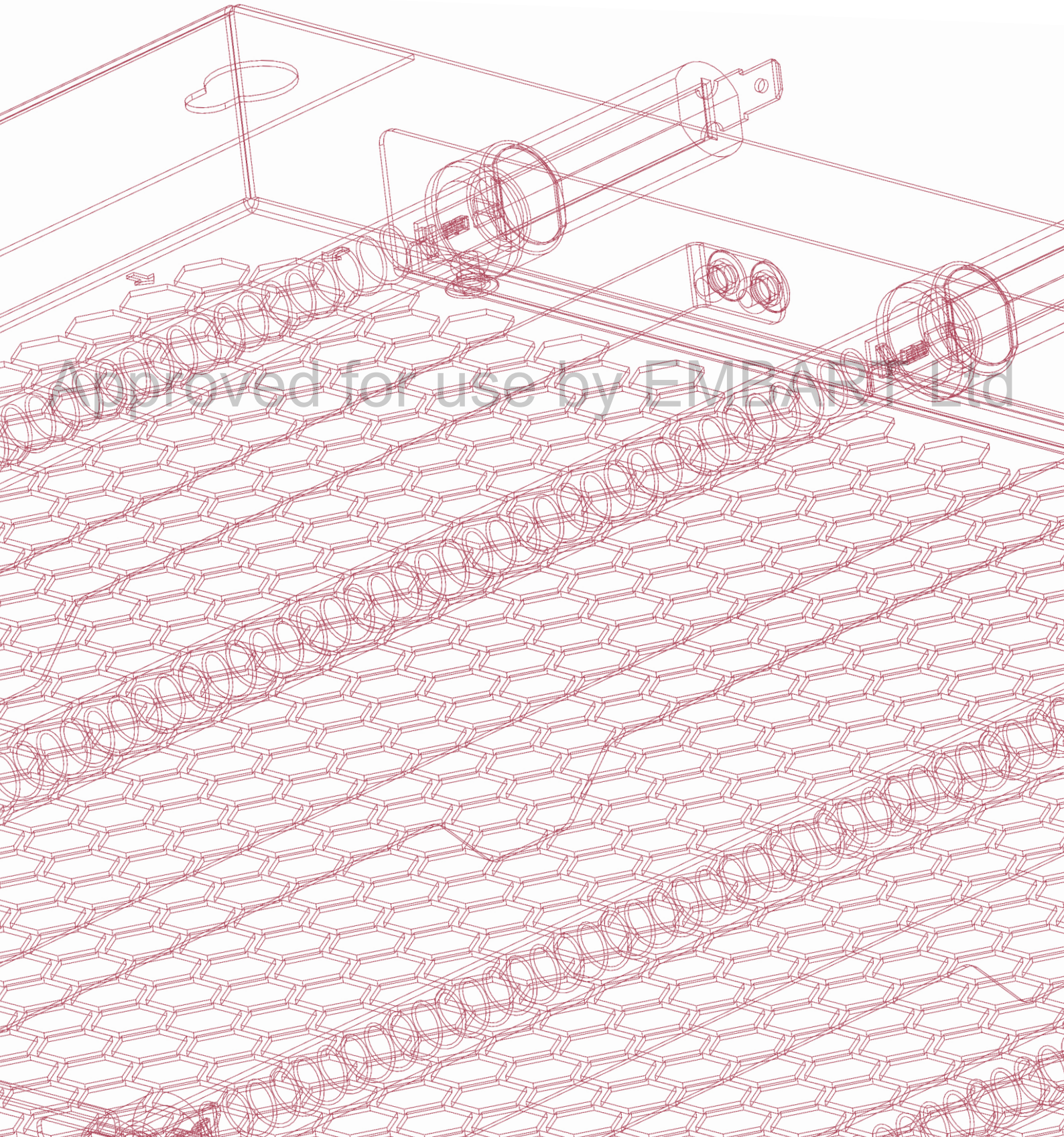

Approved for use by EMRANK Ltd

# About us

## Introduction

Bomac is a family business founded in 1976. Our industry experience spans four generations and in that time we have become one of the UK's leading companies specialising in the design, development and manufacture of heating elements and heating products.

## Market

We supply products to the UK and Worldwide markets, including some of the major global appliance manufacturers. Whilst we are capable of meeting the price, quality and volume demands of larger organisations through our far eastern manufacturing partnership, we are small enough to offer flexibility and a quick response to customer's new product requirements.



## Values

At Bomac, we take ideas and conversation through to concepts, prototyping, testing and delivery without disruption. Our seamless development process has been created over generations of working with customers to bring products, components and devices to the market.

## Certification

We are an **ISO 9001:2015** certified company meeting or exceeding the highest industry standards. Ensuring our products are safe, reliable and durable.

## Sustainability

We are working hard at refining our processes to develop products that have a reduced impact on our environment. Our passion for innovation has driven the development of new products that help our customers to move towards a more sustainable future in partnership with BOMAC.

You can find more information about our approach to sustainability on our environmental policy online.



# CSR

## Charity Support

We have an active membership with the Knowsley Chamber of Commerce and have worked closely with its members to find ways we can support others and do business better.

The Roy Castle Lung Cancer Foundation is a charitable organisation that we are currently supporting and have developed a close relationship with. The relationship with the organisation has grown on the foundation of mutual support and kindness.

The objectives are clear, we want to be a compassionate business that can improve the lives of others. Starting by caring and encouraging our staff.

Reflecting on our experiences and the experiences of others, we wanted to raise awareness within our team. We engaged in a lung health awareness workshop, focusing on the importance of exercise, diet and breathing excersises and the wearing of personal protection equipment.

If you would like to find out more, please visit our website.



## Working Well Scheme

Working with Knowsley Chamber of Commerce, we have become involved in the Working Well scheme which is dedicated to improving the health and well-being of the borough's workforce.

As part of the scheme, the business can access free services for employee well-being, support, physical health and health & safety legislation.

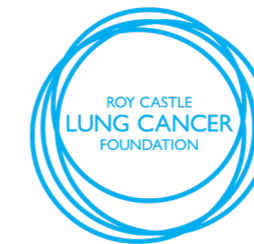

## Global Market

We supply products to both the UK & Worldwide markets. Including some of the major global appliance manufacturers.

Approved for use by EMBART Ltd

## Far-Eastern Partnership

Through our Far Eastern manufacturing partnership, we are capable of meeting the price, quality and volume demands of larger organisations. We offer a quick response and flexibility to customers new product requirements.

# Our Approach

## 01 Communicate

- Customer Focus
- Communication
- Develop good business relationships
- Understand your requirements



## 02 Collaborate

- Combine our knowledge and expertise
- Outline a concept
- Customer driven
- Build strong B2B relationships



## 03 Research & Development

- Skilled CAD capabilities
- Product testing lab
- Sustainability minded
- Experience spanning 4 generations

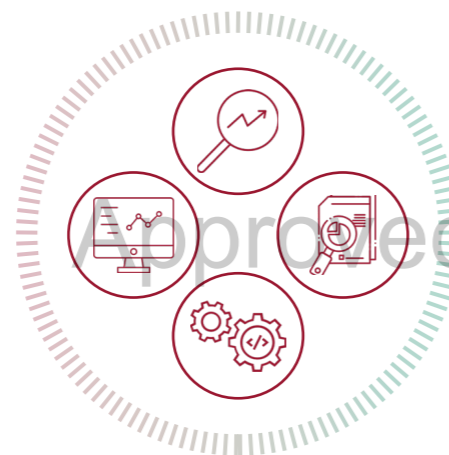

## 04 Assembly

- Fast, responsive workshop
- Prototyping / bespoke service
- Meticulous and detail focused
- Product innovation



## 05 Results

- Product innovation
- Best practice
- Achieve mutual aims
- Product realisation



Approved for use by EMBART Ltd



# Our Facilities

## Factory Refurbishment

We have been making significant improvements to our business and manufacturing facility in Knowsley, Merseyside. We have invested in brand new workstations, R&D equipment and break areas for our staff.

Our renovation project has been at the forefront of our goals, to ensure we create spaces that work for our staff and manufacturing processes, so we can be more efficient, streamlined and have a workspace that we are proud of.

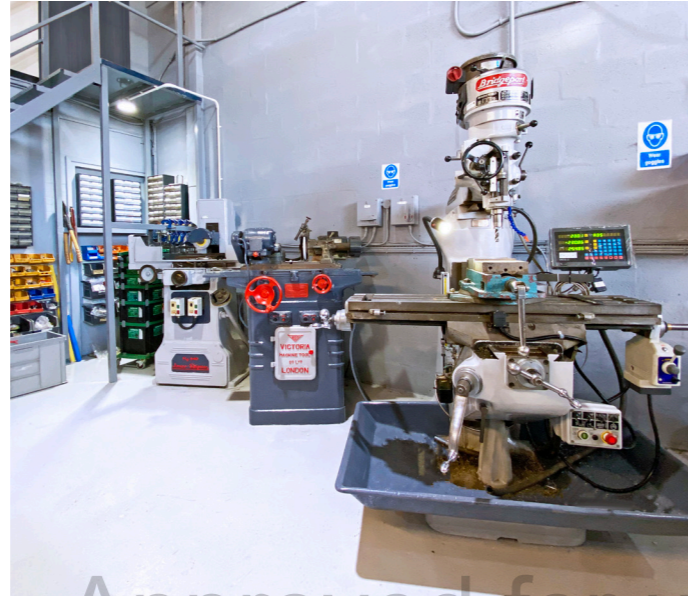

Bomac adds value by supporting applications with design, development and test resources. Our combination of skills and tools, including 2D & 3D CAD design capability, type approvals, experience and test house contacts, performance and life capabilities, support customers with integration of heating systems into the finished product.

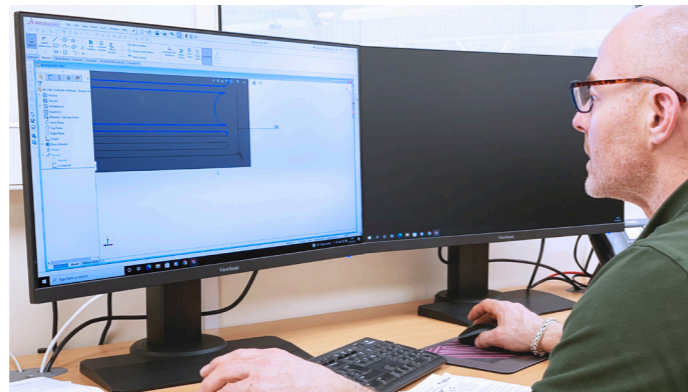

# Our Facilities

## Factory Refurbishment



Our new workstations enable us to create a clear and effective space for our assembly lines to operate. Using five step methodology to Sort, Set, Shine, Standardise and Sustain.

# Portfolio

We have built a large portfolio of products in our 50+ in business. Our strategy is to ensure we continually develop these products and be innovative in the creation of new ones.

Our business practice is part of who we are, we have been supplying electrical heating elements to major companies.

Some of our products and services and who we supply to are featured below. Please visit our website to find out more.

## We currently supply to these markets



Commercial Heating



Appliance



Commercial Catering



Packaging



Data Centre Build



Cooking Oil Management

## Product Portfolio



IBC Heaters



Aluminium Foil Heaters



Heater Coils



Heater Cable



Cooker Grills



Quartz Heating Elements



Radiant Heaters



Air Heating Elements



Metal Tubular Elements



Tangential Blower Elements



Server Emulators



Cooking Oil Management

# Product Case Study

## Lincat Cibo High Speed Oven

### Overview

We are proud to have worked with Lincat, the British manufacturer of catering equipment who have entered the high-speed oven market with their innovative 'Cibo' oven.

**01 Collaboration**  
Bomac and Lincat took a collaborative approach to combine knowledge and expertise in developing their new product.



**02 Innovation**  
Through research and development, Bomac and Lincat mutually found the winning combination of heat sources to enable Lincat to take their innovative product to the market.

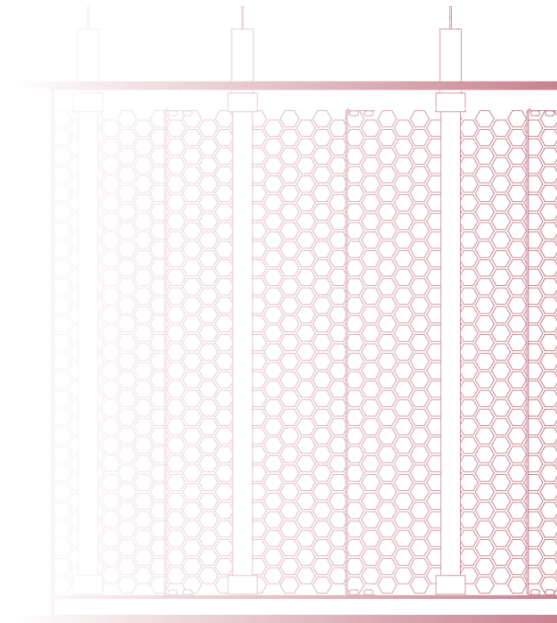

Approved for use by EMBART Ltd

**04 Results**  
The delivery is Lincats next generation, patent-pending product delivers perfectly cooked and crispy food results in a matter of **three minutes.**



**03 Implementation**  
In addition to using Bomac's High-Speed grill, Cibo uses Bomac's Infra-Tec Radiant heaters which are designed to incorporate the best in current microporous thermal insulation technology and element resistance alloy grades.

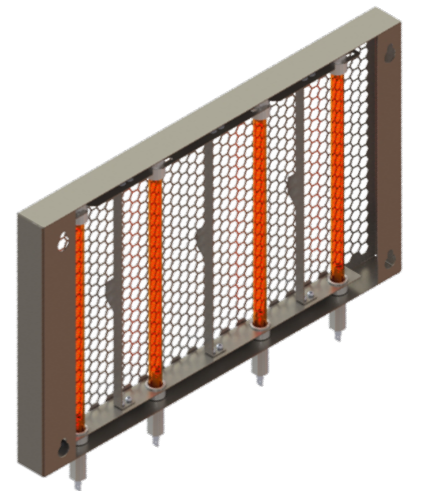

High-Speed Grill

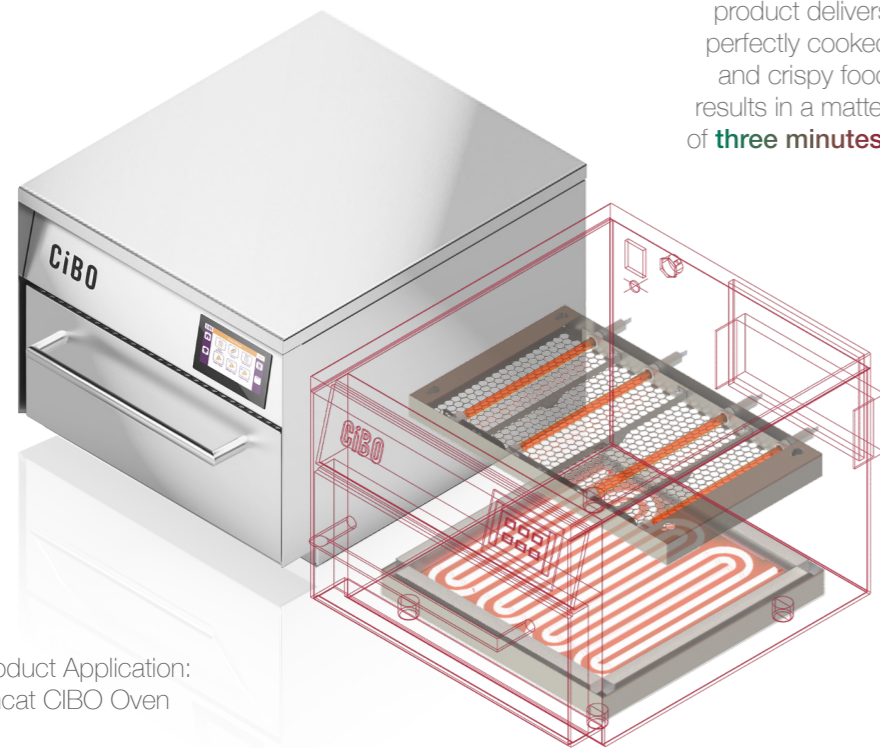

Product Application:  
Lincat CIBO Oven

*Phil Scoble, U-Select Marketing Executive wrote in the Catering Equipment Review show,*

*Lincat are a well-established British brand, who are making a foray into the accelerated oven market with the Cibo. This is a new class of accelerated oven that might just make a big dent on the UK catering market."*

High speed grill system

Foodstuff splash resistant

'Neoceram' glass-ceramic tubes

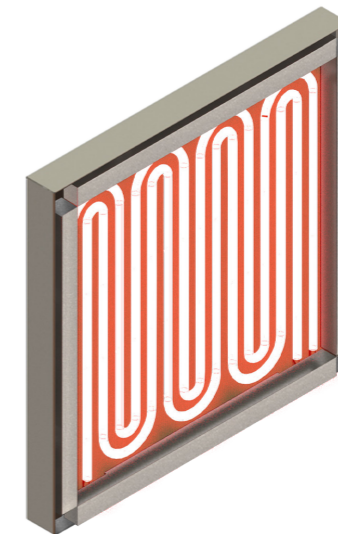

Infra-Tec Radiant Heater



Approved for use by AMBART Ltd

**BOMAC**





M

Y

CM

MY

CY

CMY

K



Certify Banner SmarTest Suite.ai 1 21/02/2023 19:21:41



**SmartTest**  
suite Powered by Exam

**Next-Generation Assessment  
Software Solutions for Education  
& Business.**

**Come and Talk to us!**  
**STAND SH30**

Info@certifyassessment.com  
www.certifyassessment.com